

FLUID COOLING | Shell & Tube UC/UCV Series

COPPER & STEEL CONSTRUCTION

Features

- Steam & Large Temperature Differentials
- Removable Tube Bundle for Servicing
- Reduces Thermal Expansion Stresses
- 3/8" Tubes
- Built-In Expansion Chamber
- Threaded or Flanged Connections
- Mounting Brackets Included
- Steel Shell Assembly

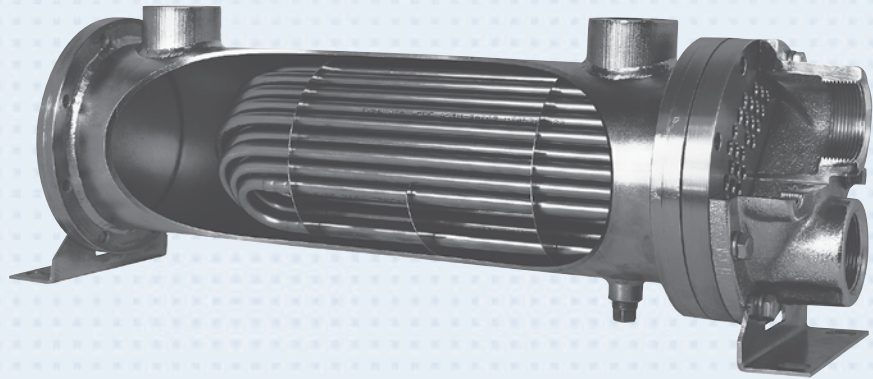

OPTIONS

- ASME Code Design
- Wide Variety of Materials Available
- Custom Sizes/Designs
- Stainless Steel Hardware and Mounting

Ratings

UC SERIES

- Maximum Shell Pressure** 250 psi
- Maximum Tube Side Pressure** 150 psi
- Maximum Temperature** 400° F

UCV SERIES

- Maximum Shell Pressure**
600, 800, 1000 250 psi
1200, 1700 150 psi
- Maximum Tube Side Pressure** 150 psi
- Maximum Temperature** 400° F

Materials UC/UCV Series

- Tubes** Copper
- Tube Sheets** Steel
- Shell** Steel/316L Stainless Steel (UCV)
- Shell Connections** Steel
- Baffles** Steel
- End Bonnets** Cast Iron
- Mounting Brackets** Steel
- Gaskets** Non-Asbestos Fiber/Nitrile Rubber
- Nameplate** Aluminum Foil

Materials USSC/USSCV Series

- Tubes** 316L Stainless Steel
- Tube Sheets** 316L Stainless Steel
- Shell** 316L Stainless Steel
- Shell Connections** 316L Stainless Steel
- Baffles** 316L Stainless Steel
- End Bonnets** 316L Stainless Steel
- Mounting Brackets** Steel
- Gaskets** Non-Asbestos Fiber/Nitrile Rubber
- Nameplate** Aluminum Foil

Dimensions

UC Two Pass

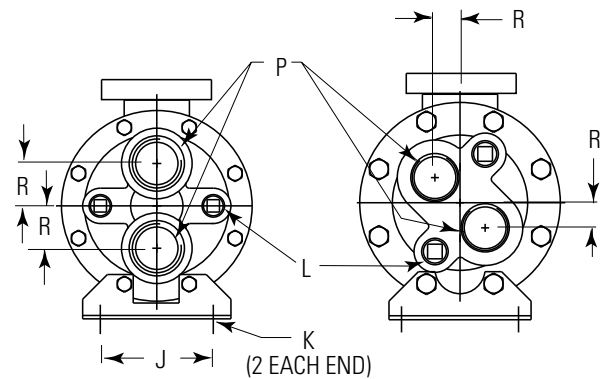
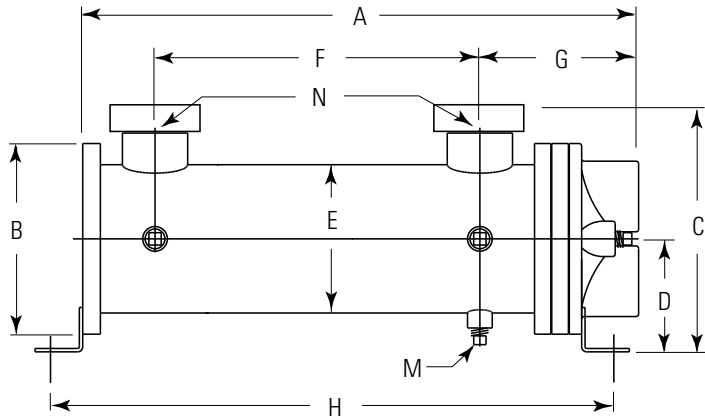

All models except
UC-800 & UC-1200 Series

UC-800 &
UC-1200 Series

MODEL	A	B DIA	C		D	E DIA	F	G	H	J	K	L NPT	M NPT	N NPT	P NPT	R	FT ² SURFACE AREA
			NPT	ASME* FLANGE													
612	17.22	4.50	5.38	6.75	2.75	3.25	11.25	4.03	17.66	3.25	.44 DIA	(2) .38	(3) .25	1.00	1.00	—	2.4
624	29.22						23.25										29.66
812	19.47	6.00	6.75	8.25	3.50	4.25	12.38	4.97	19.65	3.50	.44 DIA	(2) .38	(3) .25	1.50	1.25	0.75	4.0
824	31.47						24.38										31.65
836	43.47	6.75	7.75	9.25	4.00	5.25	36.38	5.62	43.65	4.00	.50 x .75 SLOT	(2) .38	(3) .38	1.50	1.50	1.50	11.9
1012	19.68						11.50										19.94
1024	31.68	7.75	8.75	10.38	4.50	6.25	23.50	5.89	31.94	5.00	.50 x .75 SLOT	(2) .50	(3) .38	2.00	2.00	1.10	14.5
1036	43.68						35.50										43.94
1218	26.22	7.75	8.75	10.38	4.50	6.25	17.38	5.89	26.12	5.00	.50 x .75 SLOT	(2) .50	(3) .38	2.00	2.00	1.10	15.3
1224	32.22						23.38										32.12
1236	44.22	10.50	11.58	13.00	5.75	8.62	35.38	7.81	44.12	7.00	.62 x .88 SLOT	(2) .50	(3) .38	3.00	2.50	2.25	31.3
1248	56.22						47.38										56.12
1724	34.69	10.50	11.58	13.00	5.75	8.62	23.50	7.81	34.27	7.00	.62 x .88 SLOT	(2) .50	(3) .38	3.00	2.50	2.25	47.7
1736	46.69						35.50										46.27
1748	58.69	10.50	11.58	13.00	5.75	8.62	47.50	7.81	58.27	7.00	.62 x .88 SLOT	(2) .50	(3) .38	3.00	2.50	2.25	92.5
1760	70.69						59.50										70.27

*150# ASME/ANSI Flange (Optional). NOTE: We reserve the right to make reasonable design changes without notice. Consult factory. All dimensions are inches.

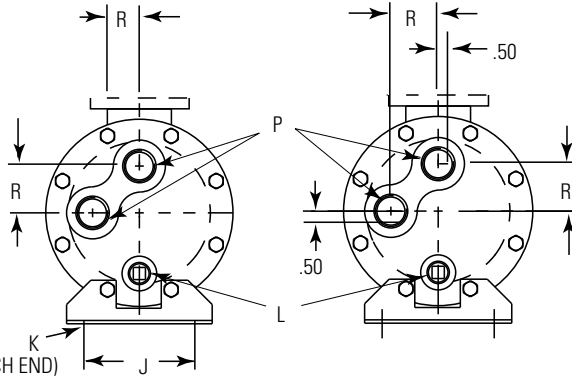
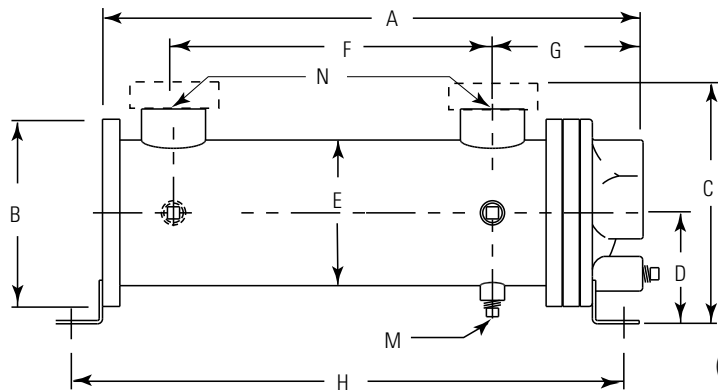

All models except UC-1700 Series

UC-1700 Series

MODEL	A	B DIA	C		D	E DIA	F	G	H	J	K	L NPT	M NPT	N NPT	P NPT	R	FT ² SURFACE AREA
			NPT	ASME* FLANGE													
612	17.20	4.50	5.38	6.75	2.75	3.25	11.25	4.01	17.66	3.25	.44 DIA	—	(3)	1.00	.75	1.00	2.4
624	29.20						23.25		29.66								4.7
812	19.47	6.00	6.75	8.25	3.50	4.25	12.00	4.97	19.65	3.50	.44 DIA	(2)	(3)	1.50	.75	1.25	4.0
824	31.47						24.00		31.65								7.9
836	43.47						36.00		43.65								11.9
1012	19.50	6.75	7.75	9.25	4.00	5.25	11.50	5.43	19.95	4.00	.50 x .75 SLOT	(2)	(3)	1.50	1.00	1.69	7.4
1024	31.50						23.50		31.95								14.5
1036	43.50						35.50		43.95								21.5
1218	26.22						17.38		26.12								15.3
1224	32.22	7.75	8.75	10.38	4.50	6.25	23.38	5.89	32.12	5.00	.50 x .75 SLOT	(2)	(3)	2.00	1.50	2.00	21.1
1236	44.22						35.38		44.12								31.3
1248	56.22						47.38		56.12								41.6
1724	34.69						23.50		34.27								47.7
1736	46.69	10.50	11.58	13.00	5.75	8.62	35.50	7.81	46.27	7.00	.62 x .88 SLOT	(2)	(3)	3.00	2.00	2.50	70.1
1748	58.69						47.50		58.27								92.5
1760	70.69						59.50		70.27								114.8

UC Applications

U-Tube Heat Exchangers allow the shell and tube bundle to expand and contract independently with temperature fluctuation. This reduces temperature dependent stresses so they are ideal in applications with large temperature differentials. Some typical examples for **UC** units include quench oil coolers, liquid to liquid heaters, and barrel oil coolers for plastic extrusion machines. The removable bundle design allows for easier cleaning of the shell side cavity when the bundle is removed.

Piping Hook-up

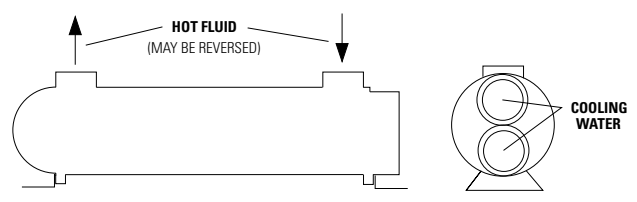

Specific applications may have different piping arrangements. Consult factory for assistance.

Dimensions

UCV Two Pass

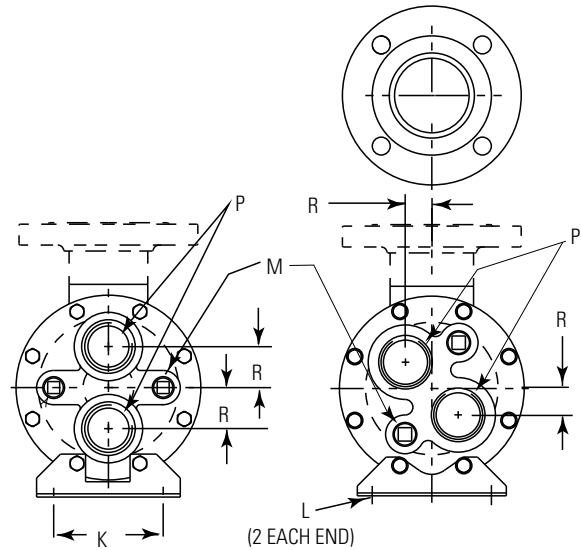
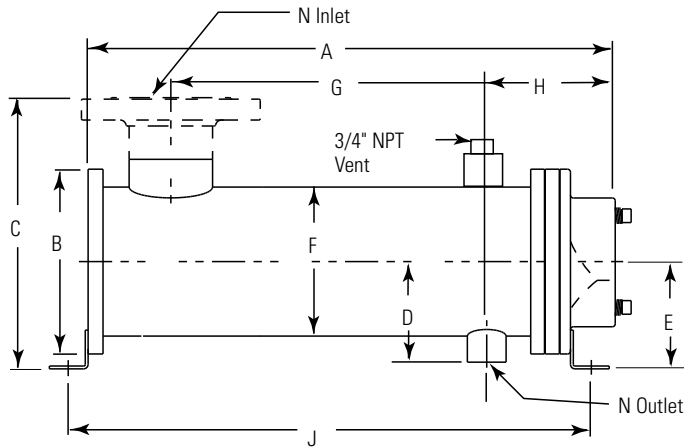

All models except
UCV-800 & UCV-1200 Series

UCV-800 &
UC-1200 Series

MODEL	A	B DIA	C	D	E	F DIA	G	H	J	K	L	M NPT	N INLET	N OUTLET	P NPT	R	FT ² SURFACE AREA
612	17.22	4.50	5.25	2.62	2.75	3.25	11.00	4.00	17.66	3.25	.44 DIA	(2) .38	1.25	.75	1.00	-	2.4
624	29.22						23.00		29.66								4.7
812	19.47	6.00	6.75	3.15	3.50	4.25	12.00	4.60	19.65	3.50	.44 DIA	(2) .38	1.50	.75	1.25	0.75	4.0
824	31.47						24.00		31.65								7.9
836	43.47						36.00		43.65								11.9
1012	19.68						11.50		19.94								7.4
1024	31.68	6.75	7.77	3.70	4.00	5.25	23.50	5.37	31.94	4.00	.50 x .75 SLOT	(2) .38	2.00	1.00	1.50	1.50	14.5
1036	43.68						35.50		43.94								21.5
1218	26.22	7.75	11.38	4.22	4.50	6.25	17.38	5.38	26.12	5.00	.50 x .75 SLOT	(2) .50	3.00*	1.00	2.00	1.10	15.3
1224	32.22						23.38		32.12								21.1
1236	44.22						35.38		44.12								31.3
1248	56.22						47.38		56.12								41.6
1724	34.69	10.50	14.00	5.58	5.75	8.62	23.00	7.31	34.27	7.00	.62 x .88 SLOT	(2) .50	4.00*	1.50	2.50	2.25	47.7
1736	46.69						35.00		46.27								70.1
1748	58.69						47.00		58.27								92.5
1760	70.69						59.00		70.27								114.8

*150# ASME/ANSI Flange. NOTE: We reserve the right to make reasonable design changes without notice. Consult factory. All dimensions are inches.



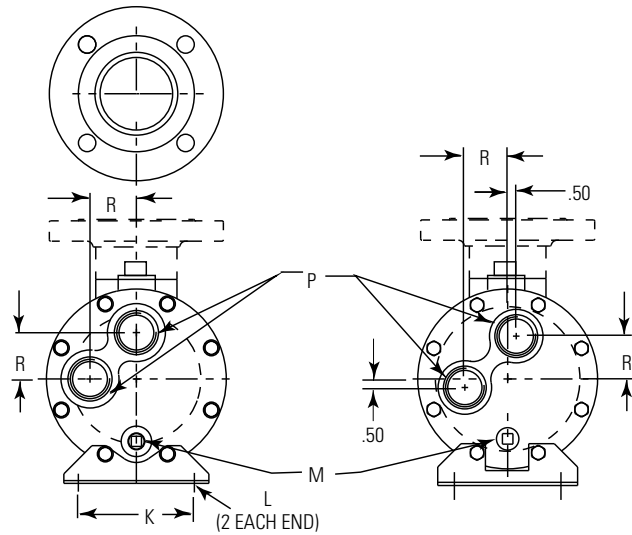
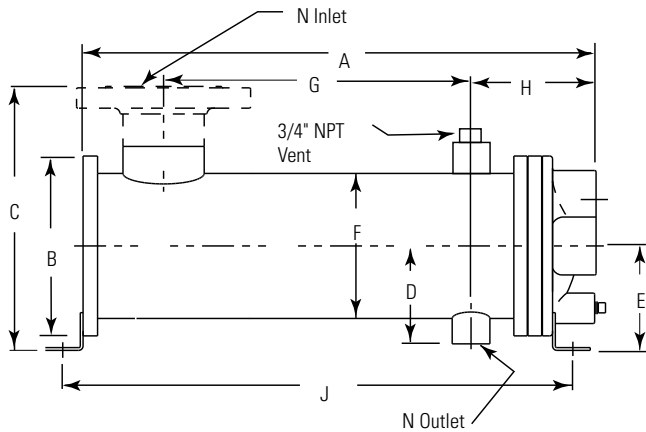

All models except
UCV-1700 Series

UCV-1700 Series

MODEL	A	B DIA	C	D	E	F DIA	G	H	J	K	L	M NPT	N INLET	N OUTLET	P NPT	R	FT ² SURFACE AREA
612	17.20	4.50	5.25	2.62	2.75	3.25	11.00	3.98	17.66	3.25	.44 DIA	(2) .38	1.25	.75	.75	1.00	2.4
624	29.20						23.00		29.66								4.7
812	19.47	6.00	6.75	3.15	3.50	4.25	12.38	4.60	19.65	3.50	.44 DIA	(2) .38	1.50	.75	.75	1.25	4.0
824	31.47						24.38		31.65								7.9
836	43.47						36.38		43.65								11.9
1012	19.50	6.75	7.77	3.70	4.00	5.25	11.50	5.18	19.95	4.00	.50 x .75 SLOT	(2) .38	2.00	1.00	1.00	1.69	7.4
1024	31.50						23.50		31.95								14.5
1036	43.50						35.50		43.95								21.5
1218	26.22	7.75	10.38	4.22	4.50	6.25	17.38	5.38	26.12	5.00	.50 x .75 SLOT	(2) .38	3.00*	1.00	1.50	2.00	15.3
1224	32.22						23.38		32.12								21.1
1236	44.22						35.38		44.12								31.3
1248	56.22						47.38		56.12								41.6
1724	34.69	10.50	13.00	5.58	5.75	8.62	23.00	7.31	34.27	7.00	.62 x .88 SLOT	(2) .38	4.00*	1.50	2.00	2.50	47.7
1736	46.69						35.00		46.27								70.1
1748	58.69						47.00		58.27								92.5
1760	70.69						59.00		70.27								114.8

UCV Applications

U-Tube Heat Exchangers allow the shell and tube bundle to expand and contract independently with temperature fluctuation. This reduces temperature dependent stresses so they are ideal in applications with large temperature differentials. Some typical examples for **UCV** units include steam to liquid heaters, vapor condensers, and steam condensers. The removable bundle design allows for easier cleaning of the shell side cavity when the bundle is removed.

Piping Hook-up

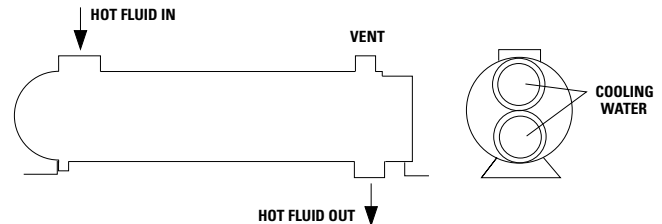

Specific applications may have different piping arrangements. Consult factory for assistance.